

LiFePO4 Battery Specification

Model: JARO BT9.12



Jarocells

Address: : Waldorpstraat 345, 2521 CJ 's-Gravenhage, The Netherlands

Registered	B. ten Berge	Customer	
Checked	R. Hurkmans	Customer Model	
Approved	J. Vermeulen		
Issued Date	01-09-2018		
Issued Version	V04		

1. General Information

This specification defines the performance specifications of the rechargeable LiFePO4 battery pack **JARO BT9.12**. Through installation of the Jarocells App on smartphone or tablet (android 4.3 or higher, iPhone 4S and higher or iPad 2 and higher) the user can read the battery pack system information.

2. Specification

NO	Items	Description	
Normal Specification			
1	Nominal Voltage	12,8V	
2	Normal Capacity	9Ah	
3	Internal Resistance	≤50mΩ	
Standard Charge			
4	Battery operation temperature range @charging	0~45°C	
5	Normal charge voltage	14,5±0,2V	
6	Recommended float charge voltage (for Standby use)	13,5 – 13,8 V	
7	Allowed MAX charge current	9A	
8	Recommended charge current	≤6A	
Standard Discharge			
9	Battery operation temperature range @discharging	-20~50°C	
10	Output Voltage Range	11,0~14,6V	
11	Allowed discharge current	15A	
12	Discharge Cut-off voltage	9,0V	
Mechanical Characteristics			
13	Dimension	Length 151±2mm	
		Width 65±2mm	
		Height 95±2mm	
14	Weight	Approx. 1,15Kg	
Storage			
15	Storage Temperature & Humidity Range	Short: within onemonth	-20~50°C, 45~85%RH
		Long term: aboveone month	5~30°C, 45~85%RH
16	Self-discharge rate	Residual capacity	≤3% per month; ≤15% per year

3. Electrical Characteristics & Test Condition

Testing Conditions: Ambient Temperature: $25 \pm 5^{\circ}\text{C}$; Humidity: 45%~75%.

NO	Items	Criterion	Condition	
1	Internal Impedance	$\leq 50\text{m}\Omega$	Test the internal resistance of 50% SOC battery pack with 1 kHz AC internal resistance test instrument.	
2	Capacity	$\geq 7,2\text{ Ah}$	Rest for 1 hour after fully charged, then discharge with 0.33C current until the battery reaches the discharge cutoff voltage. Repeat above process for three times, if the discharge time is not less than 180 minutes, you can stop and define the Discharging current*time value (Ah) as battery capacity.	
3	Short circuit protection	Automatically cutoff discharging when short circuit, and release after connecting charger	Connect the positive and negative of the battery pack through a lead with a resistance of less than 5 m Ω . Disconnect short cut and connect charger to restore.	
3	MAX chargeCurrent	9A	Charging with this current for more than 0.5h and the added temperature of battery pack less than 10°C .	
4	Recommended discharge Current	9A	Discharging with this current for more than 0.5h and the added temperature of battery pack less than 10°C .	
5	Cycle life (DOD%100)	≥ 1000 cycle Remaining capacity > 7,2Ah	Discharge with the current of 0.5C until it can't discharge, and then rest it for 1h. Charge the battery following CC(0.33C)/CV(14.6V) mode to full capacity, and then rest it for 1h. Repeat above process until full charged capacity is no more than 80% of normal value. Accumulated times is defined as cycle life.	
6	Discharge Temperature Characteristics	-20 $^{\circ}\text{C}$	$\geq 60\%$	At $25 \pm 5^{\circ}\text{C}$ discharge the battery with the current of 0.33C to the cut-off voltage. Store the battery at various temperatures for 2h and discharge the battery with 0.33C to the cut-off voltage. Record the ratio between discharging & charging capacity.
		0 $^{\circ}\text{C}$	$\geq 80\%$	
		25 $^{\circ}\text{C}$	100%	
		55 $^{\circ}\text{C}$	$\geq 95\%$	
7	Charge Retention ability	remain capacity $\geq 90\%$	Charge the battery to full capacity and store it for 28 days, and then discharge it with 0.33C to the cut-off voltage.	

4. Circuit Protection

The batteries are supplied with a LiFePO4 Battery Management System (BMS) that can monitor and optimized each single prismatic cell during charge & discharge, to protect the battery pack overcharge and over discharge. Overall, the BMS helps to ensure safe and accurate running.

Test item	Content	Criterion
Over charge	Over-charge protection for each cell	3.80±0.03V
	Over-charge release for each cell	3.60±0.05V
	Over-charge release method	Under the release voltage
Over discharge	Over-discharge protection for each cell	2.30±0.05V
	Over-discharge release for each cell	2.40±0.05V
	Over-discharge release method	Over the release voltage
Over current	Discharge over current protection	~35 - 48A instantly, >15A <5 sec
	Protection delay time	7~16ms
	Over current release method	Release after cutoff the loads.
Short circuit	Connection impedance	Removal short circuit, connect charger

5. Dimensional Drawing

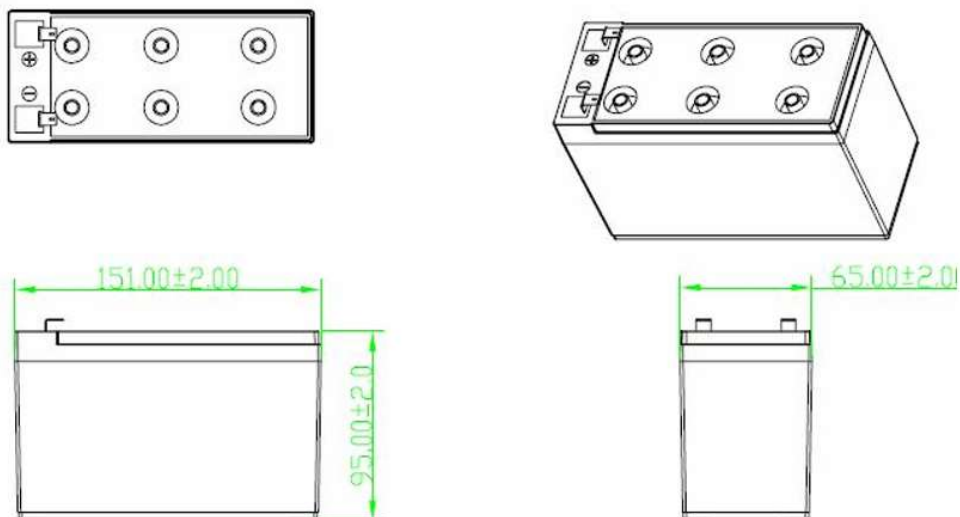

6. Storage & Transportation

- * Based on the character of cell, proper environment for transportation of LiFePO₄ battery pack need to be created to protect the battery.
- * Battery should be stayed in the ware house -20°C~35°C where it's dry, clean, shade, and well-ventilated. When stored for a period of longer than one year 5 – 30°C.
- * The battery should be stored in approx. 50 % SOC during transportation (air freight 30%)
- * The battery need to be charged every 6 months if out of use
- * Keep the battery against dropping, turning over and serious stacking during loading.

7. Warning & Tips

Please read and follow the specification and caution remarks on battery surface before use the battery. Improper use may cause heat, fire, rupture, damage or capacity deterioration of the battery.

Warning!

- * The battery must be far away from heat source, high voltage, and avoid to be exposed in sunshine for longtime.
- * Never throw the battery into water.
- * Never connect the positive and negative of battery with metal.
- * Never ship or store battery together with metal.
- * Never reverse two electrodes when use the battery.
- * Never disassemble the battery without manufacturer's permission and guidance.
- * Never knock, throw or trample the battery.

Tips!

- * Keep the battery against high temperature. Otherwise it will cause battery heat, get into fire or lose some function and reduce the life.
- * When battery run out of power, please charge your battery timely (≤ 15 day).
- * Please use the matched or suggested charger for this battery.
- * If battery emit peculiar smell, heating, distortion or appear any abnormality during working or storage, please stop using and take it out from device.
- * If the battery leaks and get into the eyes or skin, do not wipe, instead, rinse it with clean water and see doctor immediately.
- * Please far away from children or pets.
- * Do not put scrap battery into a fire or water.
- * If user needs to parallel several battery packs, please charge them to full capacity with same type of matched charger, and set it aside for 8 hours, professionals only. This battery pack supports application no more than 8 group parallel. If user needs to apply this product to more groups parallel, please reconfirm details with us.
- * It is strictly prohibited any series between the battery packs without consulting Jarocells because of special requirements needed.